

Briquette Saw

BS350

Top of the line Briquette Saw for high productivity consumer briquetting plant. We have upgraded our BS 350 saw to the latest EU standards and offer a unique solution in combining the saw with our BW 350 in-line check weighing system. The BS 350 briquetting saw is an ideal solution for briquetting plants producing consumer type briquettes, and are looking to cut them in uniform length (+/- 2 mm) in order to pack them into a typical foil wrapped package of 10 kg i.e.

Floating saw

The BS 350 has been constructed as a "floating saw" as it grips around the briquette string, and moves forwards by the force of the strokes from the briquetting press. Meanwhile it cuts the briquettes into the desired length. A pneumatic cylinder moves the cutter back to its starting position.

Long cooling line

30m of cooling line is recommended, in order to allow the briquette string to cool down and harden before entering the saw. A sorting system

will push out any briquettes that are broken or of differing length to avoid disturbance in a connected packaging system (Requires automatic sorting option).

Collection and reuse of sawdust

Narrow saw blades with hardened teeth are used to minimize the amount of saw dust that has to be sucked away from the cutting area by a suction device and can be delivered back to the storage silo via a cyclone and be briquetted again.

Safety first

As a consequence of our high concern for operator safety, all moving parts of the cutter have been totally encased in a metal housing and safety switches have been installed to avoid any accidents. The housing cannot be opened until the saw blade has come to a complete stop.

Main features

Fulfills the latest EU standard for saws, EN1870-3+A1: 2001+A1: 2009:

- Brake time for saw blade
- Safety circuit for door
- Surveyed service hatches
- Reduced noise level
- Nominal briquette length adjustable from control panel
- Length deviation +/- 2 mm
- Integrated length/ breakage control removes non-proven products (option)
- Alarm for drop in air pressure
- Air nozzle for removal of saw dust from center hole in briquettes
- Metal detector recommended for production of center hole briquettes
- Can be combined with BW350 in-line check-weighing system

Technical specifications

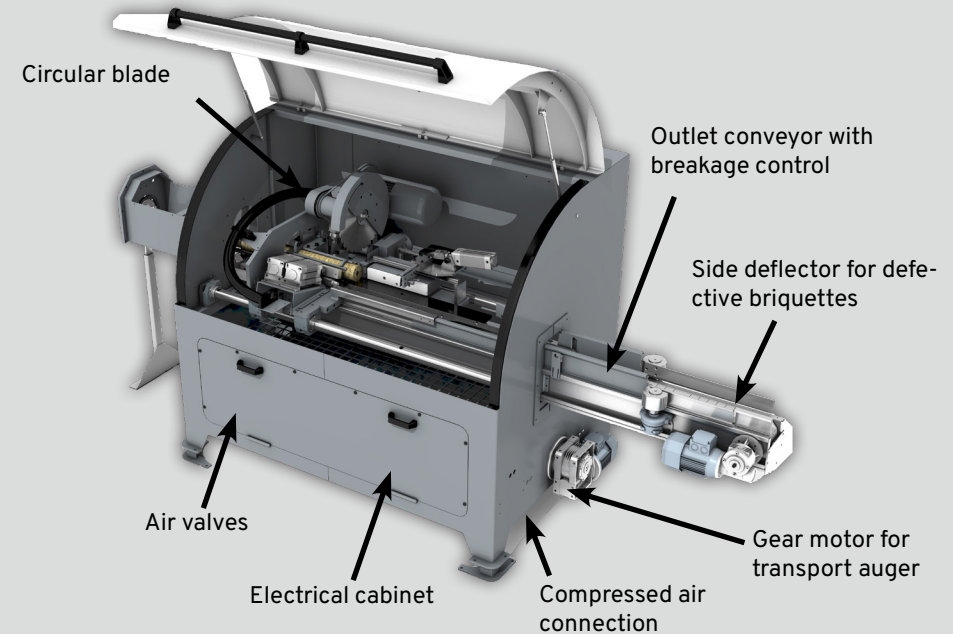

Specifications	BS 350 Briquette Saw
Briquette Diameter	Ø60 - Ø100 mm
Manuel Length Adjustment	150 - 375 mm (+/- 2mm)
Electronic Length Adjustment	220 - 370 mm (+/- 2mm)
Cycle time	20 cuts/minute
Main Motor	3 kW
Compressed air pressure	7 bar
Suction connections for sawdust	Ø100 mm x 2
Dimensions L x W x H (m)	1,7 x 1,1 x 1,5 m
Weight	900 kg